

4

3

2

1

TABLE		
PART NUMBER	DESCRIPTION	ITEM-3
721579011	NS 4.5 2100 6x350 SPC-MAX LED 120 VAC	4742003
721579012	NS 4.5 2100 6x350 SPC-MAX LED 240 VAC	4742004



REVISION HISTORY				
ECN	REV	DESCRIPTION	DATE	APPROVED
12181	00	INITIAL RELEASE	5/23/2014	RCC
12435	A	Added 721579012	11/3/2014	RCC

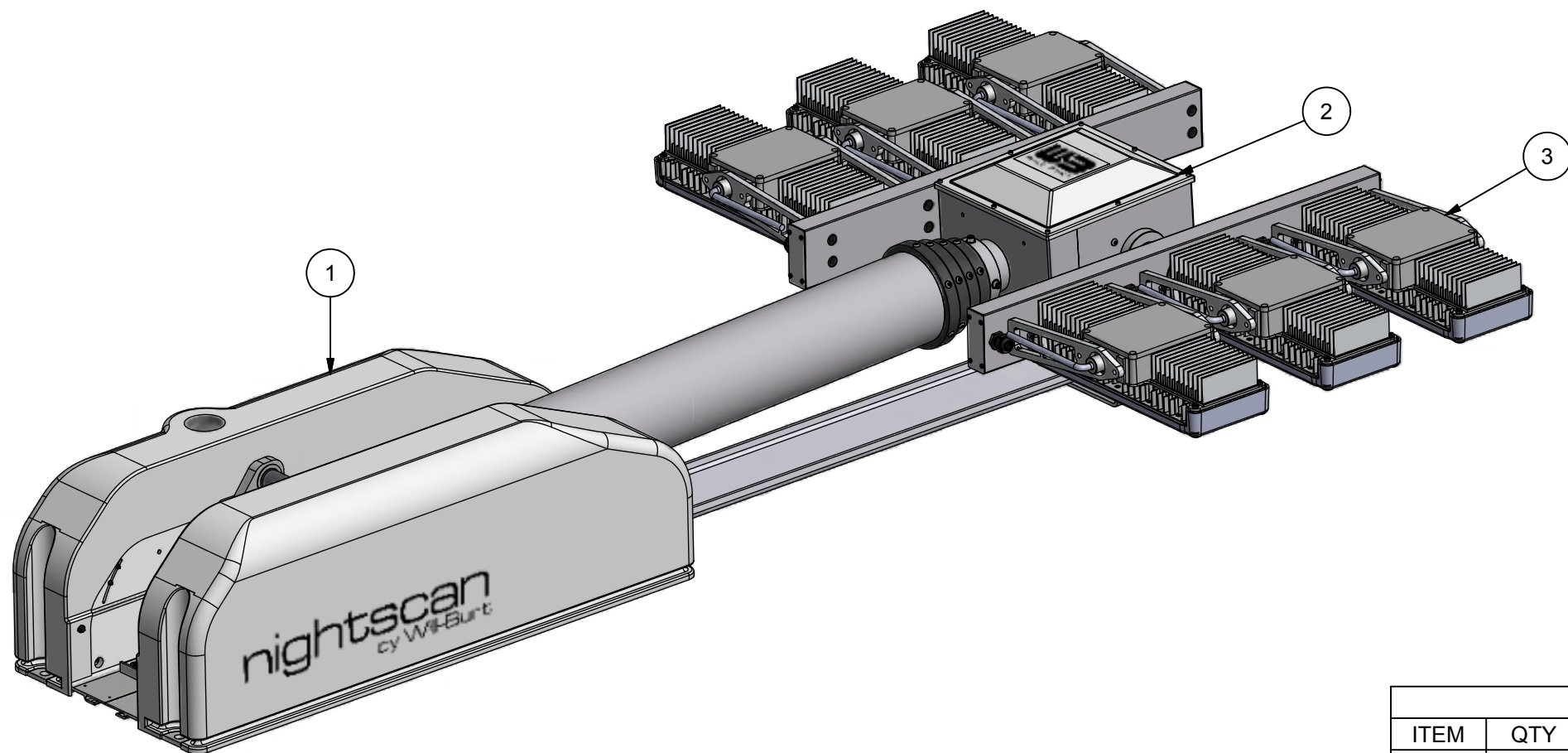

BOM			
ITEM	QTY	PART NUMBER	DESCRIPTION
1	1	4627601	BASE ASSEMBLY NSP 15 FT. CLR ADZ
2	1	4742521	RCP ASSEMBLY NSP STD NO-SHAFTS CLR
3	1	SEE TABLE	LIGHT, KIT SPC-MAX 2100 (6X350W)
4	1	4706703	LABEL KIT-CLEAR CE (NOT SHOWN)
5	1	TP-4723701	NSP MANUAL CD (NOT SHOWN)
6	1	WD-46276	WIRING DIAGRAM

UNLESS OTHERWISE SPECIFIED DIMENSIONS ARE IN INCHES.
 TOLERANCES ON DECIMALS ANGLES
 0 = ± 0.030 ± 1°
 00 = ± 0.020
 000 = ± 0.015

1. ALL INSIDE EDGES TO HAVE .005" TO .035" FILLETS.
 2. ALL OUTSIDE EDGES TO HAVE .005" TO .015" CHAMFER OR RADIUS.
 125° ON ALL MACHINED SURFACES

PROPRIETARY AND CONFIDENTIAL
 THE INFORMATION CONTAINED IN THIS DRAWING IS THE SOLE PROPERTY OF THE WILL-BURT COMPANY ANY REPRODUCTION IN PART OR WHOLE WITHOUT THE WRITTEN PERMISSION OF THE WILL-BURT COMPANY IS PROHIBITED.



TITLE
 NS 4.5 2100 6x350 SPC-MAX LED 120 VAC

APPROX. WT:N/A
 THIRD ANGLE PROJECTION

APPROVALS	DATE	SIZE	DWG NO	REV
DRAWN RCC	5/23/2014	B	721579011	A
CHECKED		PN:	SEE TABLE	SHEET 1 OF 2

4

3

2

1

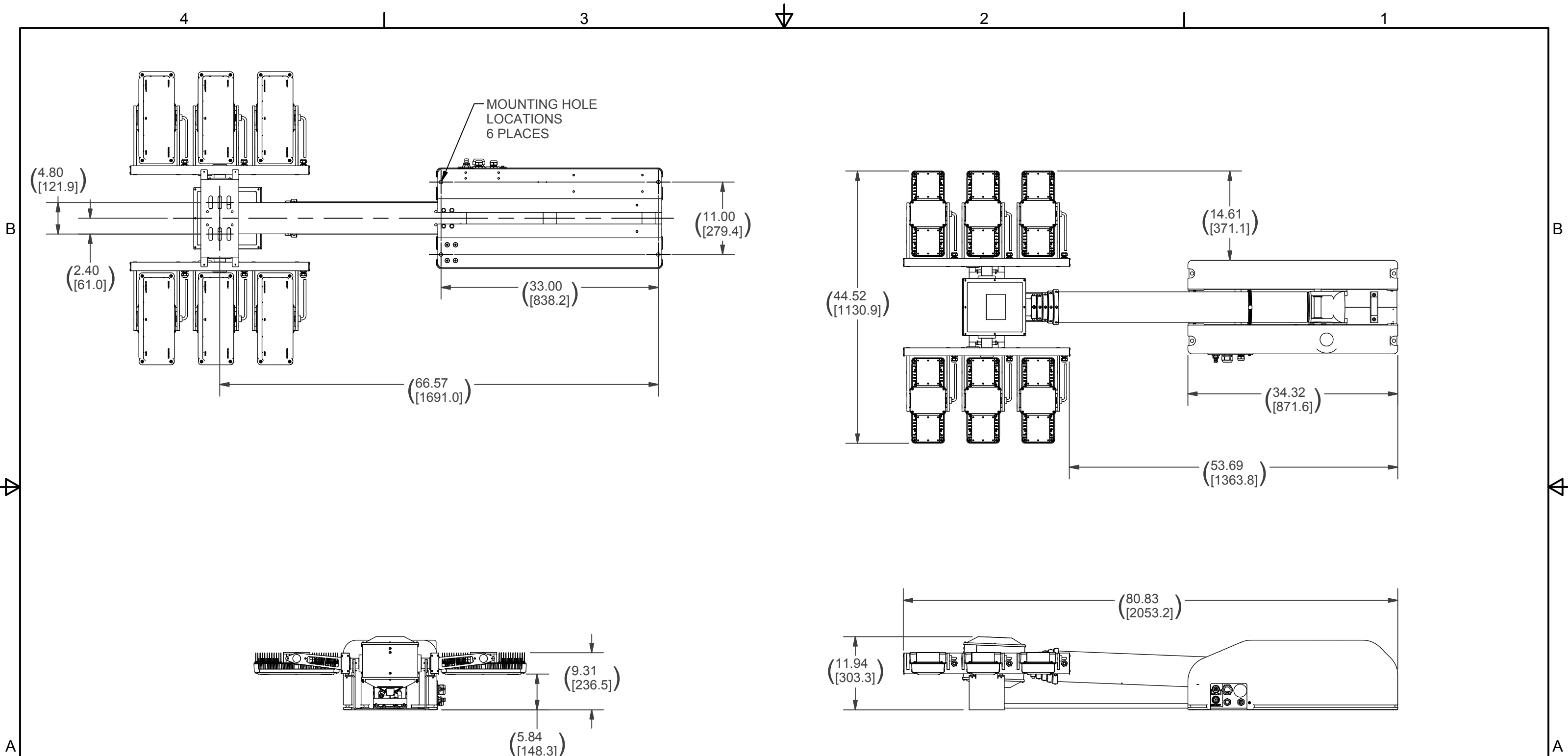

APPROX. WT:N/A
 THIRD ANGLE PROJECTION

UNLESS OTHERWISE SPECIFIED DIMENSIONS ARE IN INCHES.
 TOLERANCES ON DECIMALS ANGLES
 0 = ± 0.030 ± 1°
 00 = ± 0.020
 000 = ± 0.015
 1. ALL INSIDE EDGES TO HAVE .005" TO .035" FILLETS.
 2. ALL OUTSIDE EDGES TO HAVE .005" TO .015" CHAMFER OR RADIUS.
 125 ON ALL MACHINED SURFACES

PROPRIETARY AND CONFIDENTIAL
 THE INFORMATION CONTAINED IN THIS DRAWING IS THE SOLE PROPERTY OF THE WILL-BURT COMPANY ANY REPRODUCTION IN PART OR WHOLE WITHOUT THE WRITTEN PERMISSION OF THE WILL-BURT COMPANY IS PROHIBITED.

APPROVALS	DATE
DRAWN RCC	5/23/2014
CHECKED	

W3 AN EMPLOYEE OWNED COMPANY
 WILL-BURT ORRVILLE, OH
 TITLE
NS 4.5 2100 6x350 SPC-MAX LED 120 VAC

SIZE B	DWG NO 721579011	REV A
PN: SEE TABLE	SHEET 2 OF 2	