

REVISION HISTORY				
ECN	REV	DESCRIPTION	DATE	BY/APPR
11466	00	INITIAL RELEASE	2/4/2013	RCC\

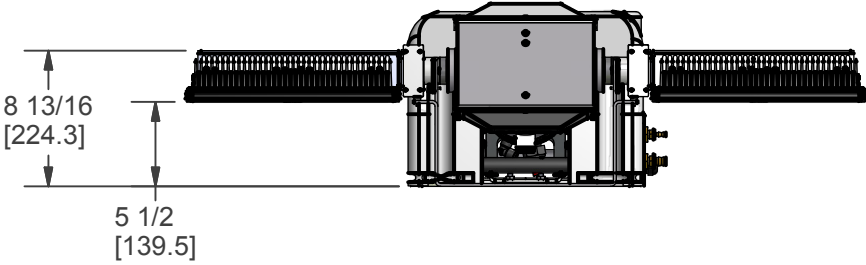

NOTES:
SECONDARY DIMENSIONS - MILLIMETERS NOTED IN BRACKETS

APPROX. WT:199.6 lbmass

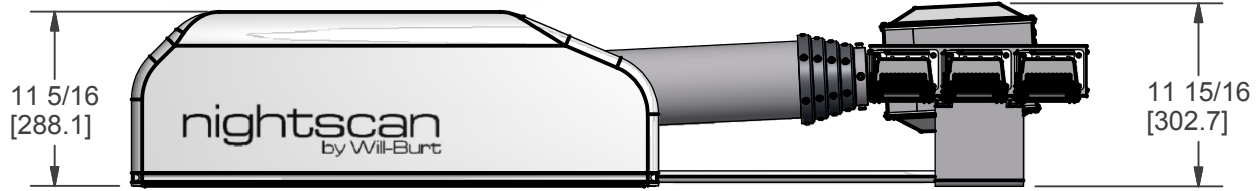
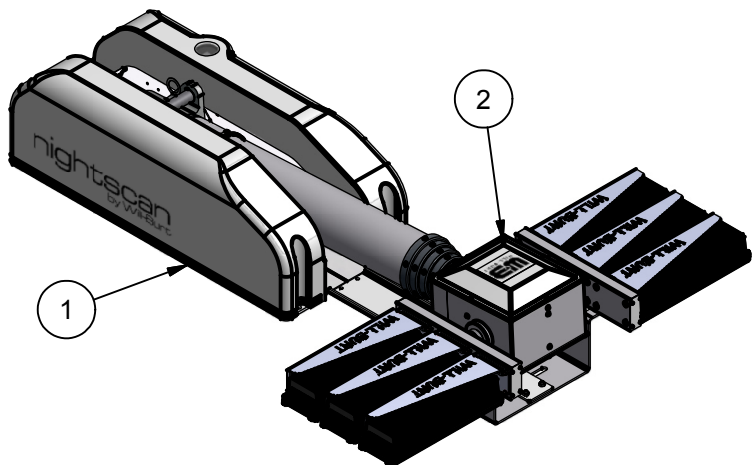
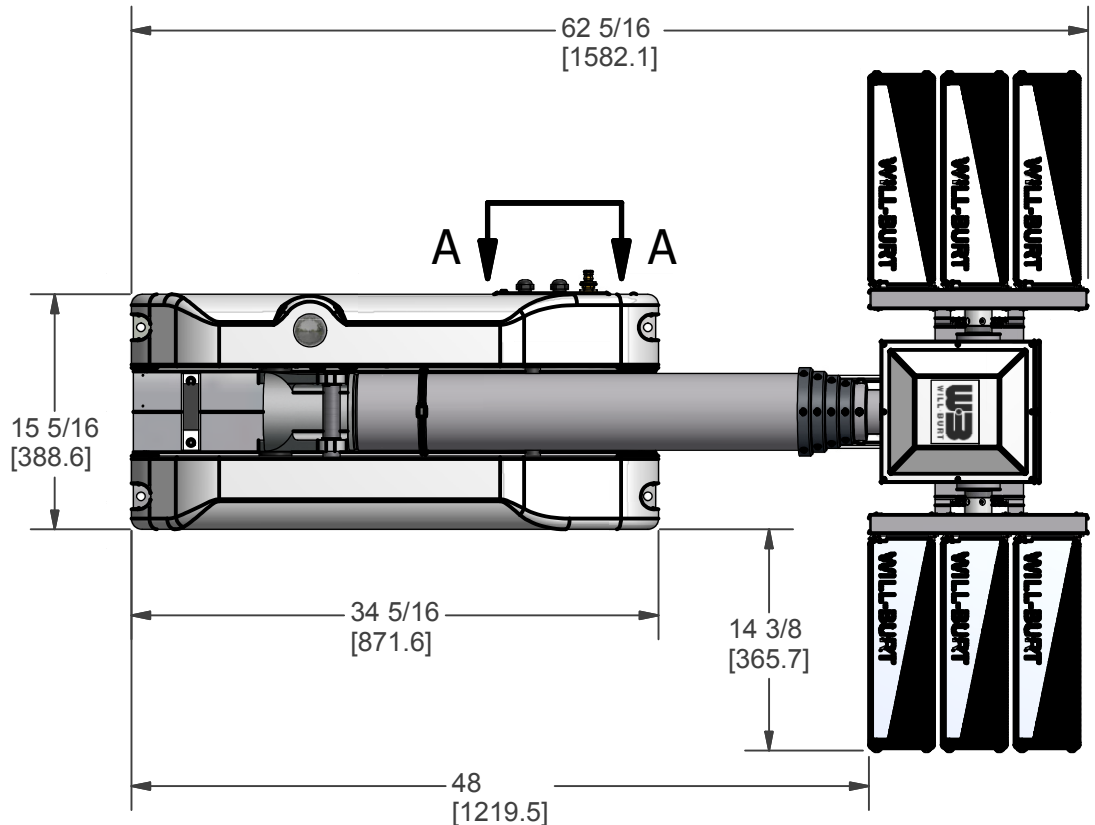

UNLESS OTHERWISE SPECIFIED DIMENSIONS ARE IN INCHES.
TOLERANCES ON DECIMALS ANGLES
0 = ± 0.030 ± 1/2°
.00 = ± 0.015
.000 = ± 0.010
FRACTIONAL ± 1/64"
1. ALL INSIDE EDGES TO HAVE .005" TO .035" FILLETS.
2. ALL OUTSIDE EDGES TO HAVE .005" TO .015" CHAMFER OR RADIUS.
125√ ON ALL MACHINED SURFACES

PROPRIETARY AND CONFIDENTIAL
THE INFORMATION CONTAINED IN THIS DRAWING IS THE SOLE PROPERTY OF THE WILL-BURT COMPANY ANY REPRODUCTION IN PART OR WHOLE WITHOUT THE WRITTEN PERMISSION OF THE WILL-BURT COMPANY IS PROHIBITED.

W3 AN EMPLOYEE OWNED COMPANY
WILL-BURT ORRVILLE, OH

TITLE
**NS 3.0 900 WHL LED
110V- SPT/FLD**

APPROVALS	DATE
DRAWN RCC	2/4/2013
CHECKED	

SIZE	DWG NO	REV
B	721030002	00
PN: 721030002		SHEET 1 OF 2

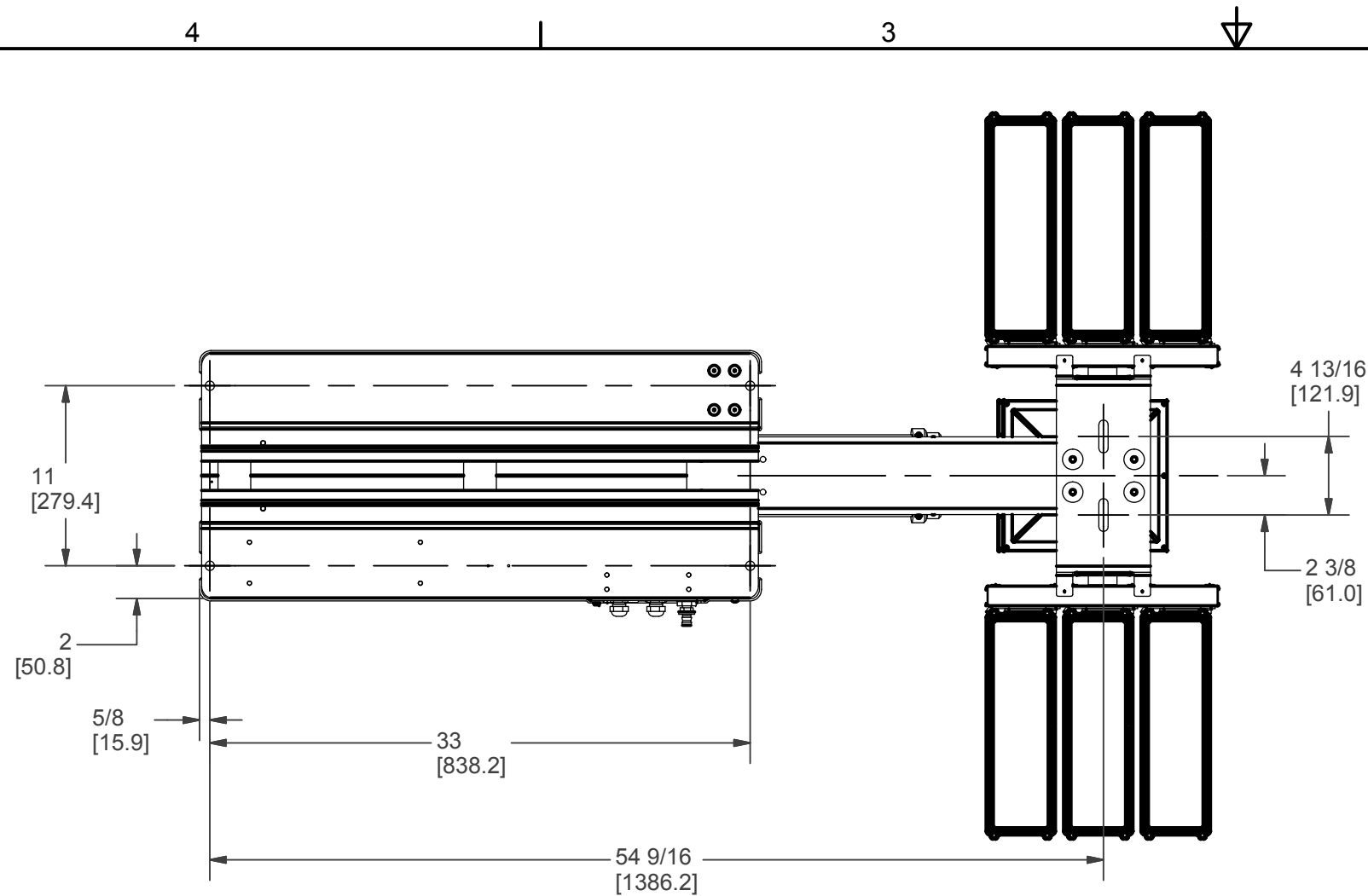

BOTTOM VIEW
MOUNTING BOLT PATTERN

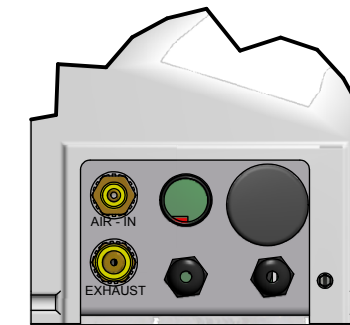

SECTION A-A
ROTATED 180°

NOTES:

- 1 APPLY RTV #739 OR EQUAL TO ALL OPEN HOLES
- 2 SEE WIRING DIAGRAM WD-47397 FOR WIRING DETAILS
- 3 SET LIGHT BARS HOME POSITION PARALLEL TO BASE PLATE WHEN STOWED
- 4 APPLY LOCTITE #242 OR EQUAL TO ALL THREADS UNLESS OTHERWISE NOTED
- 5 APPLY A COAT OF SILICONE GREASE TO RCP MOTOR BORES PRIOR TO SHAFTS BEING INSTALLED
- 6 INSTALL GROUND WIRE ASSEMBLY TO BOARD AND RCP HOUSING

APPROX. WT:199.6 lbmass

THIRD ANGLE PROJECTION



**UNLESS OTHERWISE SPECIFIED
DIMENSIONS ARE IN INCHES.**
TOLERANCES ON DECIMALS ANGLES
0 = ± 0.030 ± 1/2°
.00 = ± 0.015
.000 = ± 0.010
FRACTIONAL ± 1/64"
1. ALL INSIDE EDGES TO HAVE
.005" TO .035" FILLETS.
2. ALL OUTSIDE EDGES TO HAVE
.005" TO .015" CHAMFER OR RADIUS.
125√ ON ALL MACHINED SURFACES

BOM			
ITEM	QTY	PART NUMBER	DESCRIPTION
1	1	4627603	BASE ASSEMBLY NSP
2	1	4742501	RCP ASSEMBLY NSP STD
3	1	4794901	WHELEN LED 6LTS 900W(6-150W120VAC)SPDFLD
4	1	4706701	NSP LABEL KIT (NOT SHOWN)
5	1	4807801	KIT, SHIPPING NSP (NOT SHOWN)

PROPRIETARY AND CONFIDENTIAL
THE INFORMATION CONTAINED IN THIS DRAWING IS THE SOLE PROPERTY OF THE WILL-BURT COMPANY ANY REPRODUCTION IN PART OR WHOLE WITHOUT THE WRITTEN PERMISSION OF THE WILL-BURT COMPANY IS PROHIBITED.

WILL-BURT AN EMPLOYEE OWNED COMPANY
ORRVILLE, OH

TITLE
**NS 3.0 900 WHL LED
110V- SPT/FLD**

APPROVALS	DATE	SIZE	DWG NO	REV
DRAWN RCC	2/4/2013	B	721030002	00
CHECKED		PN:	721030002	SHEET 2 OF 2