

Stiletto HD



6 meter model

Features and Benefits



The Stiletto HD electro-mechanical mast (28VDC) is a revolutionary screw-drive telescoping mast designed for communications, reconnaissance, and surveillance applications. The Stiletto HD is lightweight and mobile and allows internal or external mountings for MRAP or shelter installations. Built with durable, high strength carbon fiber composite tube sections, the Stiletto HD is designed and tested to meet MIL-STD-810 environmental standards for operations in extreme conditions.

Features:

Non-rotatable self-locking sections

- Allows Stiletto HD to lock at any height without power for increased safety for personnel and payload
- Provides tight antenna pointing accuracy

Does not require guylines

- Allows for quick and easy setup and fast deployment

Enhanced controls

- Provides height read-out
- Computer interface and operation option

Electric drive for extension and retraction

- Provides positive retraction against ice

Easy maintainability

- Five minute in-field routine maintenance
- Easy disassembly and reassembly for depot maintenance

Standard finish is polyurethane green enamel #34094

- CARC and other polyurethane colors available



Stiletto HD



6 meter model

Mast and Standard Equipment

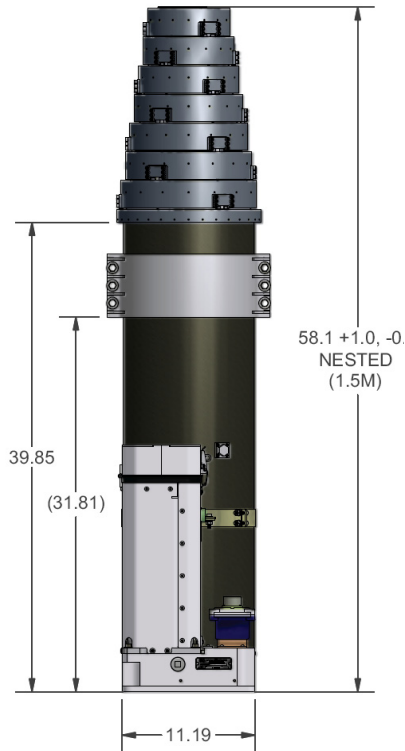

Nested View

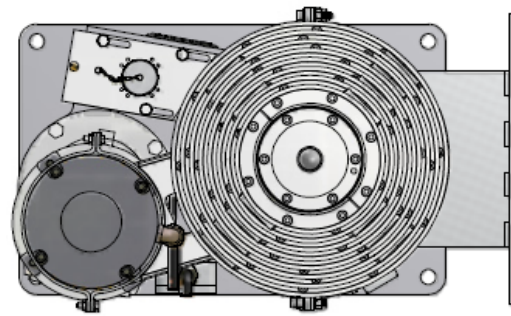

Top View

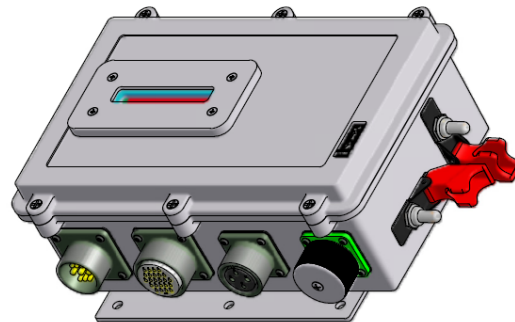

Control Box

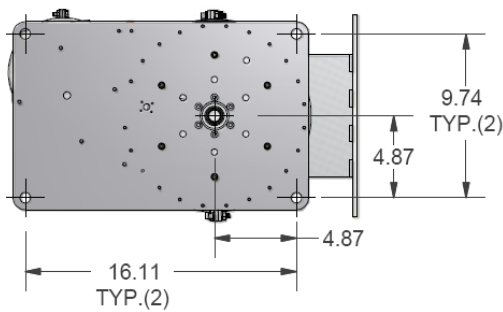

Mounting Interface

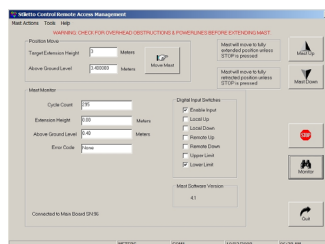

SCRAM Software

Computer interface that allows the user full function of the Stiletto HD including height readout and diagnostics.

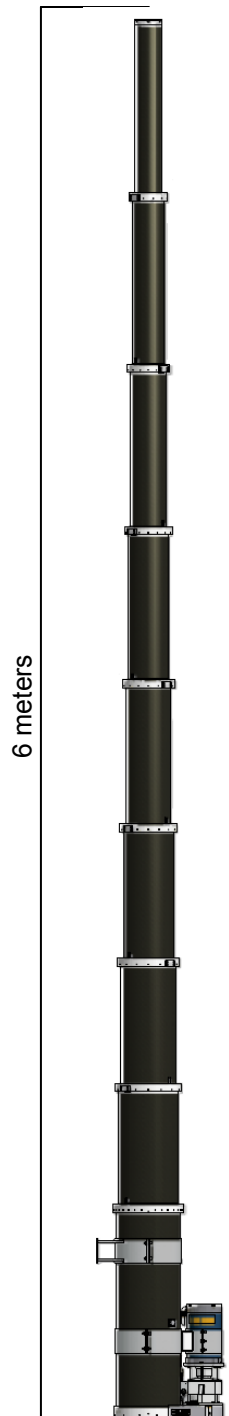

Stiletto HD



6 meter model

Optional Equipment

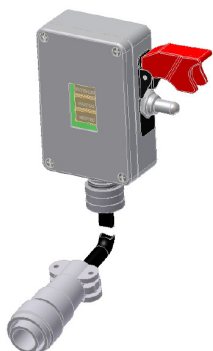

Handheld Remote Control

Secondary mast Up/Down switch that allows the user to walk outside the vehicle or the ability to operate the Stiletto from two locations.

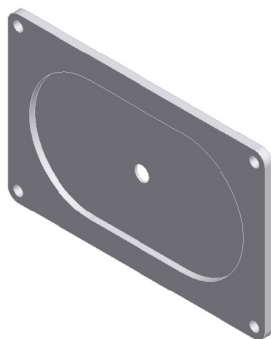

Drain Plate

When the Stiletto is mounted internally through the roof of a vehicle the drain plate catches the water and debris so it does not enter to the floor of the vehicle.



Manual Crank

Allows manual operation of the Stiletto.

Stiletto HD



6 meter model

specifications & MIL-STD qualifications

Specifications	6 meter
Nested height (+1 in./-0 in.)	58 in./1.5 m
Extended height (+4 in./-0 in.)	19.67 ft./6 m
Payload Capacity	400 lb./180 kg
Erection time with power	35 sec.
Typical payload sail area	11 sq. ft./1.0 sq. m CD=1.5
Deployment wind speed	40 mph/60 km/hr
Survival wind speed	100 mph/150 km/hr
Voltage	28 VDC
Weight including control box & cables	340 lb./154 kg
Rotation accuracy (twist)	+/-1°
Footprint	17.56 in. x 11.19 in./ .44.6 cm x 28.4 cm



Stiletto HD — MIL-STD 810F Qualifications

Altitude / Sea level to 15,000 feet per MIL-STD-810F, Method 500.4

Transportation / Altitude / Sea level to 15,000 feet (unpressurized) MIL-STD-810F, Method 500.4

Storage Temperature Ranges / -44°C to +70°C MIL-STD-810F, Method 501.4 and 500.4

Operating Temperature Ranges / -44°C to +55°C MIL-STD-810F, Method 501.4 and 502.4

Solar Radiation / Per MIL-STD-810F, Method 505.4

Rain / Per MIL-STD-810F, Method 506.4

Humidity / Per MIL-STD-810F, Method 507.4

Fungus / Per MIL-STD-810F, Method 508.5

Salt Fog / Per MIL-STD-810F, Method 509.4

Sand and Dust / Per MIL-STD-810F, Method 510.4

Ice and Freezing Rain / Per MIL-STD-810F, Method 521.2

)